

RTI INSTRUCTION AND OPERATING MANUAL

Compressor installation SiloKing 1500
Powerband driven





Preface

This instruction and operating manual is required for compressor installations manufactured by the following company:

RTI Transport Installaties B.V.
Albert Schweitzerstraat 29
7131 PG Lichtenvoorde
Tel. + 31 (0)544-377050

The manual provides information about the following installation:

CVS 1500 powerband DRIVEN

Carefully read these instructions and the compressor instruction before setting up and going into operation. These manuals contain essential information that must be read to ensure interference-free operation and to achieve longevity.

Repairs, maintenance or conversion work shall only be carried out by authorised, trained and qualified personnel that are familiar with the current safety regulations.



Contents:

1	General	4
1.1	Contact details	4
1.2	Service facilities	4
1.3	Technical data compressor	4
1.4	Oil SiloKing compressors	5
1.5	Oil cooler	6
2	Safety	7
2.1	General	7
2.2	Qualification and training personnel	7
2.3	Operating safety-conscious	7
2.4	Safety instructions operator	7
2.5	Modifications and repairing spare parts	7
2.6	Modifications installation	7
3	Mounting installation	8
3.1	Mounting instructions RTI installation powerband driven	8
3.2	Mounting instructions high air intake	9
4	Start-up	10
5	Maintenance installation	11
5.1	Inspection during operation	11
5.2	Weekly inspection	12
5.3	Monthly inspection	13
5.4	Half-yearly inspection	14
5.5	Maintenance checklist	15

1 General

1.1 Contact details

Please mention the PO number when contacting us by phone or mail. You will find the PO number on the type plate of the installation.

Telephone number: (0031) 544-377050
 Fax: (0031) 544-376499
 Email: info@rti.nl

1.2 Service facilities

For addresses of service/technical support facilities, please visit our website www.rti.nl

1.3 Technical data compressors

SiloKing performance characteristics ¹⁾		Unit	Model 1500		
Input speed		[min ⁻¹]	1000	1500	2000
Intake volume flow at a final overpressure at the pressure flange	0,0 bar	[m ³ /h]	770	1220	1640
	2,0 bar		690	1140	1560
	2,5 bar		670	1120	1540
Coupling power at a final overpressure at the pressure flange	0,0 bar	[kW]	14	26	40
	2,0 bar		41	62	85
	2,5 bar		48	71	96
Final temperature at final overpressure = 2,0 bar		[°C]	180	176	176

1) Intake pressure at the suction flange = 1.0 bar, suction and ambient temperature = 20 °C

Tab. 1: Performance characteristics

Permissible working range	Unit	Model 700	Model 1100	Model 700 LS	Model 1100 LS	Model 1500
Input speed ⁰⁾	[rpm]	2400...3600	2000...3600	1950...2930	1630...2930	1000...2000
Compressor weight	[kg]	117	127	126	135	185
Compressor weight with adapter gear	[kg]	157	167	166	175	–
Suction temperature ¹⁾	[°C]	– 10...+ 40				
Geodetic height ¹⁾	[m]	0...1000				
Negative pressure suction side (e.g. due to soiling)	[mbar]	0...65				
Maximum final overpressure at the pressure flange ²⁾	[bar]	2.5				
Running time in continuous operation ³⁾	[h]	max. 3.0				
Permissible inclination from the horizontal	[°]	±10				±3

0) When installing an adapter gear, the drive speed reduces according to the transmission used.

1) For suction temperatures or heights outside the permissible working range, consult with CVS.

2) In case of increased suction temperatures or heights, the maximum permissible final pressure is reduced. Consult with CVS.

3) For continuous operation in excess of 3 hours, an oil cooler must be installed. Installation instructions on request.

Table 2: Permissible working range

Image 1.3.1

1.4 Oil SiloKing

Gear oil specification	Value
Specification	API CD/SF or higher, respectively MIL L-2104C or higher
SAE viscosity class	10W40 or 15W40
Oil pressure	min. 0.5 bar (excess pressure)
Gear oil quantity compressor ¹⁾	
Model 700 / 1100	8 litres
700LS / 1100LS	7 litres
1500	6.8 litres
Gear oil quantity adapter gear:	
Model 700 / 700 LS / 1100 / 1100LS	
Drive shaft top	1.1 litres
Drive shaft right and left	1.5 litres

1) When connecting a gear oil cooler, the oil quantity must be increased commensurate with the additional volume.

Types of gear oil	Brand	Type of oil
	CVS ¹⁾	CVS-LUB 2000
	ARAL	Multi Turboral SAE 15W40
	DEA	Cronos Super DX SAE 15W40
	ESSO	Essolube XT 201 SAE 15W40
	SHELL	Universal Engine Oil SAE 15W40
	FUCHS	Titan Universal HD SAE 15W40
	BP	Vanellus C5 Global SAE 15W40

1) You may purchase the high performance oil CVS-LUB 2000 from CVS. Using this special oil doubles the oil change interval to 1 year or 1000 operating hours respectively and extends the warranty period to 2 years.

Note: Food grade oil available on request

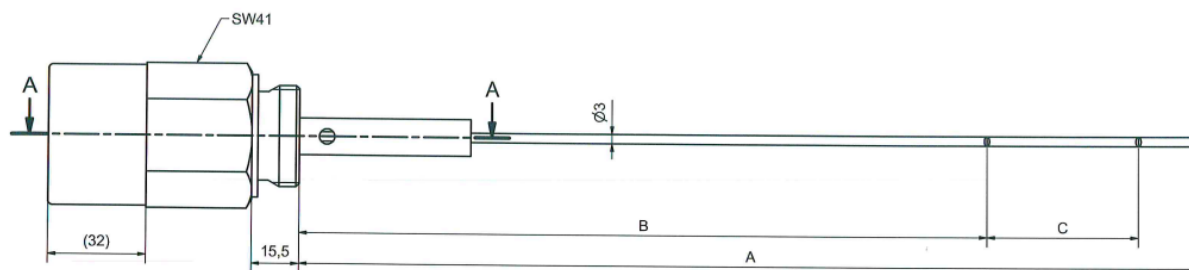

Längen Ölpeilstab

Artikel Nr.	Typ	A	B	C
438 020-00	SKL 700/1100	295	225	50
438 020-01	SKL 700/1100 verlängert	360	290	50
438 021-00	SKL 700/1100 LS	300	241	35
438 021-01	SKL 700/1100 LS verlängert	365	306	35
438 022-00	SKL 1500	345	273	29

1.5 Oil cooler

When operating continuously over 3 hours, an oil cooler must be installed. When installing the oil cooler the oil volume should be increased by a volume equal to the extra flow rate.



Image 1.5.1 Oil cooler (art.no. 1342)

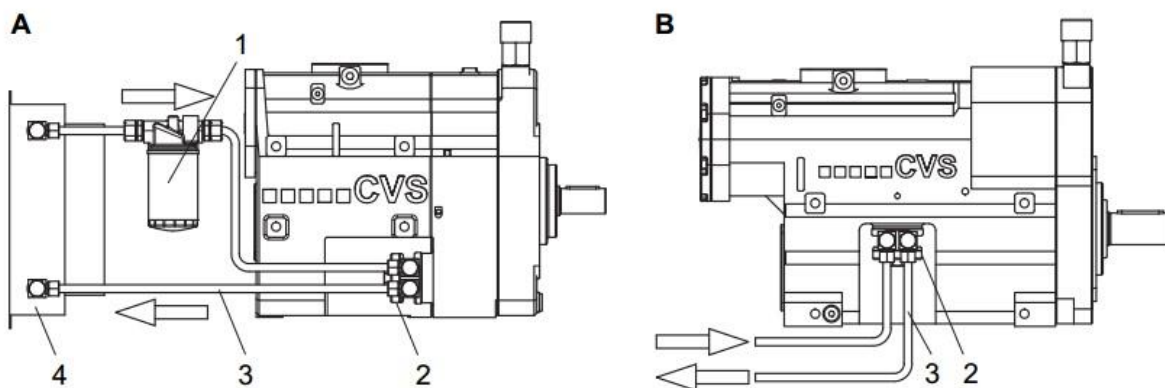

A: SiloKing 700 / 1100 / 700 LS / 1100 LS

B: SiloKing 1500

Note: Adequate oil cooler can be obtained from CVS.

Fig. 6: Oil cooler

- 1 Oil filter in the return flow
- 2 Adapter for external oil circulation
- 3 Line to the oil cooler
- 4 Oil cooler with ventilator

Image 1.5.2



2 Safety

2.1 General

This operating manual provides important information concerning operation and maintenance of the installation that must be observed. Authorised personnel/the operator must read the manual carefully before going into operation and the manual must be kept in direct proximity of the installation.

2.2 Qualification and training personnel

Any work on the compressor such as operation and maintenance shall only be carried out by authorised, skilled and qualified personnel, who are familiar with the applicable safety regulations. Repairs, maintenance and conversion work shall only be carried out by authorised personnel.

2.3 Operating safety conscious

Essential safety regulations relating to the setting up, operation and maintenance of air compressors are covered by the following publications:

- Regulations for the prevention of accidents, in particular:
 - VBG 16 compressors
- Standards, in particular:
 - DIN EN 12100 Safety of machines
 - DIN EN 1012-1 Compressors and vacuum pumps, safety requirements

The latest edition of each of these regulations shall be applicable. Any special official codes and regulations, particularly safety regulations applicable to your operation in view of the local conditions shall be observed likewise. In the event of competing regulations, the most severe requirements shall apply.

2.4 Safety instructions operator

Securing the compressor's operational safety is the responsibility of the operator. Damaged or non-functioning parts must be replaced immediately. If combustible materials are to be handled by the compressor, it shall be ensured that the spontaneous-ignition temperature of any dust/air mixture will not be reached. VBG 16 prescribes that a temperature limit of max. 120° C should not be exceeded (measuring point prior to contact with the conveyed product).

2.5 Modifications and repairing spare parts

Unauthorized repair work and modifications are not permitted. Warranty doesn't apply to installations with a damaged seal. Original spare parts and accessories approved by the manufacturer contribute to safety. Using foreign spare parts and accessories may entail the loss of any liability for the consequences arising therefrom.

2.6 Modifications installation

Without approval from RTI, it is not permitted to make any alterations to the installation.



3 Mounting installation

3.1 Mounting instructions RTI installation powerband driven

- A While placing the installation on a pallet, make sure the installation is approximately 30 cm off the ground (raising the installation with timber if necessary).
- B Drive the installation up to the desired location next to the truck. Make sure the angle of the drive shaft is as small as possible. **Please find the maximum mounting angle in the mounting instructions provided by the truck manufacturer.**

The resulting angle can be 15° maximum!
1° to 10° is good
11° to 15° is excessive

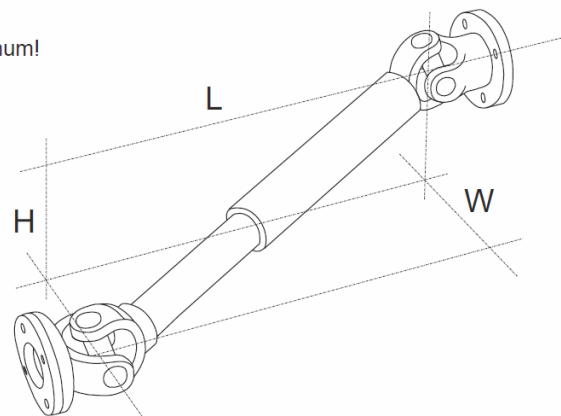

Image 3.1.1

- C Place the installation at the same level as the chassis and parallel to the truck. Measure the PTO-shaft. Make sure the installation doesn't exceed the width of the truck.
- D Measure the brackets and try to use all the holes in the chassis. Brackets should be painted or otherwise protected against corrosion.
- E The installation must be mounted with at least 3 brackets. (With a box or tank combination at least 4 brackets should be used)
- F Mark where the holes need to be, drill/punch the holes, paint the brackets in the colour of your choice and let them dry.
- G Mount the painted brackets onto the chassis with the bolts and nuts specified by the manufacturer.
- H Subsequently mount the installation onto the brackets with M14 bolts (8.8), washers, spring washers and nuts.

NOTE

With a vacuum installation the vacuum valve must be set to -0.5 bar. Please note: the vacuum valve should be set when testing the installation before initial operation. The vacuum valve has not been set when the installation is delivered as a building kit (without mounting by RTI).

3.2 Mounting instructions high air intake

- A Mount the high air intake behind the drivers cab with the supplied rubber buffers and blind riveting nuts.
- B Mount the flexible hose between the air filter and the high air intake.
- C Use safety rubbers or suspension brackets when attaching the hose between the chassis with tie wraps.
- D Check the functionality of the sliding joint connected to the high air intake; check to see if it can be taken off. The sliding joint should separate from the high air intake before the drivers cab is tilted.
- E Check the negative pressure after mounting (this should not be below 45 mbar).



Image 3.2.1



4 Start-up

Observe the following prior to start-up:

IT IS OF VITAL IMPORTANCE THAT THERE ARE NO PERSONS UNDERNEATH THE VEHICLE DURING START-UP AND DURING OPERATION!!

● Preservation

The rotors of the compressor are sprayed with an anti-corrosion agent prior to delivery. During the initial operation this agent will evaporate as the compressor heats up. Since the RTI-installations are all tested a few minutes, the anti-corrosion agent on the rotors will have evaporated.

● Topping up of lubricating oil

Check before start-up if the correct amount of lubricating oil is on the dipstick. The correct level corresponds to the mark on the dip stick. See chapter 1.4

● Checking the direction of rotation

Looking towards the drive shaft, the compressor must rotate clockwise.

The compressor must be started and stopped in a fully unloaded condition, without any back pressure.

Never start against any back pressure. (Remove blanking cap or connect hoses.)

● Switching-on

We refer to the truck's instruction booklet, to switch on the PTO (only with closed enclosure).

It is very important not to exceed the maximum speed range as reported in the inspection report and as displayed on the dashboard of the driver's cab.

Together with the compressor, the integral oil pump will also start to run and will ensure the supply of oil to lubricate the bearings and the gears. The oil pressure shall not fall below 0,3 bar. With cold oil, it may occur that the required oil pressure is built up only after a short operating time, due to higher viscosity. Check the air indicator clock. When "red", the compressor must be switched off. See inspection checklist.

● Vacuum installation

With a vacuum installation the vacuum valve must be set to -0.5 bar. Please note: the vacuum valve should be set when testing the installation before initial operation. The vacuum valve has not been set when the installation is delivered as a building kit (without mounting by RTI).

CAUTION

After a short period of time, the compressor will reach maximum running temperature.

When switched-on, it not permitted to loosen the catches on the enclosure!!

We recommend the use of safety gloves when disconnecting hoses or couplings from the enclosure, after the installation has been switched-on.

NOTE

When cleaning the tank vehicle by means of a steam jet device, water may penetrate inside the compressor via the oil seals. To avoid corrosion, the compressor shall be set into operation for a short period of time after cleaning.

The non-return valve installed in the discharge silencer is not intended to prevent flow-back of material. Its purpose is to prevent the reverse operation of the compressor for an extended period of time.

It is not permitted to use the attached relief valve as blow-off control valve.



5 Maintenance installation

5.1 INSPECTION DURING OPERATION

- A: Check the oil manometer before every start-up. The oil pressure must not drop below the minimum value of 0.3 bar, (normally 1-3 bar). When outside temperature is low it may take a few seconds before the oil pressure is visible.
- B: Check the air filter indicator.
If the red mark is visible, the air intake filter is soiled and poses a risk of overheating and damages.
- C: The safety valve must open at maximum air pressure.
This valve must NOT be used as blow-off valve. To prevent overheating in the enclosure the valve at the silo tank must blow off before the compressor valve does. (blow-off pressure 2.5 bar)
- D: Pay attention to any unusual sounds or peculiarities near the installation.

5.2 WEEKLY INSPECTION

ONLY CARRY OUT WHEN INSTALLATION IS COOL AND AT A STANDSTILL

- A: Check the level of lubricating oil weekly.
To achieve longevity of the compressor it is important the oil level remains between the indicated marks on the dip-stick (do not overfill).
- B: Check the air intake filter at regular intervals. Clean or replace the air filter if necessary.
* Please note that the air filter is reinserted in the same position (paying attention to the front and back of the element).



Image 5.2.1

Also check the functioning of the air indicator.

- C: It is important to check the airflow and cleanliness of the fan louvres to prevent overheating of the compressor.
(compressed air cooler and when installed the oil cooler)
- D: Check the tension of the V-belt/powerband and assess the wear of the belt.
Retighten the belt if you can press over 0.5 centimetre into the belt.

5.3 MONTHLY INSPECTION

ONLY CARRY OUT WHEN INSTALLATION IS COOL AND AT A STANDSTILL

This check may only be carried out by skilled mechanics. Observe the safety very carefully, the enclosure must be removed and rotating parts will be accessible.

- A: Lubricate cross journals of the PTO-shaft (after approx. 40 operating hours)
- B: Lubricate latches and padlock and check their functioning.
- C: Preserve the compressor when it has been at a standstill for a longer period of time. (lubricate the compressor's rotor with oil to prevent corrosion)

To carry out the following inspections it is necessary to start the installation without enclosure. Please note the dangers that can occur as a result of access to:

- hot parts as compressor and silencer (150 ° C)
- rotating parts such as the transmission and the fan
- high sound levels (> 85 dB)

HEARING PROTECTION OBLIGATED!!

DURING INSPECTION NO ONE IS ALLOWED UNDERNEATH THE VEHICLE!!

- D: Check the functioning of the safety valve.
 Air pressure measured at the discharge flange of the compressor may not exceed a maximum gauge pressure of 2.5.
Potential pressure loss between compressor and silo tank of 0.2 up to 0.3 bar
- E: Check flanges/packing, rubber compensators etc. in the enclosure for air leakages to avoid loosening of the insulation material and overheating.
- F: Check the tension of the belts/powerband. Retighten the belts if your can press over 0.5 centimetre into the belt.

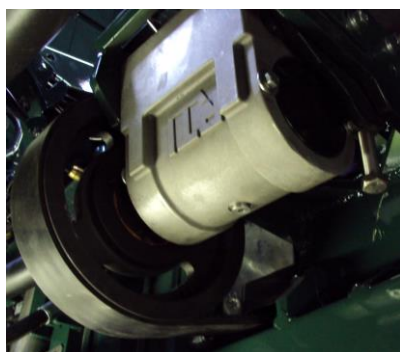

Stainless steel tension bolt M16x140 art.no. 16140

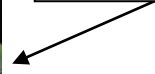

Image 5.3.1



5.4 HALFYEARLY INSPECTION

ONLY CARRY OUT WHEN INSTALLATION IS COOL AND AT A STANDSTILL

This check may only be carried out by skilled mechanics. Observe the safety very carefully, the enclosure must be removed and rotating parts will be accessible.

- A:** Change the lubricating oil simultaneously with the truck's engine oil, at least twice a year.
(oil type SAE 10W40)
- B:** Change the oil filter.
- C:** Demount the non-return valve installed in the discharge silencer and check for proper functioning.
- D:** The aluminium bearing block (type 405) is supplied with 200 ml. oil (ISOVG68). Check the seals for damages/leakage.
Change the oil every 4 years (or every 3,500 hours).

NOTE:

The operating instructions provided by the compressor manufacturer should be read carefully.

5.5 Maintenance/inspection list

Along with every maintenance inspection the maintenance checklist on the next page must be filled out. We recommend sending the checklist to RTI after filling it out.

Mail: info@rti.nl
Fax: (0031) 544-376499

Hold on to the checklist, the checklist can be handed to the mechanic when the next maintenance service is due or when the installation needs to be repaired. (Do not forget to take the checklist back with you)

Maintenance checklist



Firma	:	Date maintenance	:
Name mechanic	:	Compressor	:
Address	:	Serial number	:
	:	Installation-no.	: PO.....
Truck	:	Year manufactured	:
Truck nr.	:		:
Licence plate no.	:	Chassis:	No. KM driven:

Actions

COMPRESSOR:

- Drain oil
- Clean oil filter
- Clean magnetic plugs
- Check potential leakage machine
- Change + top up oil
- Check oil hose for potential cracks/damages

SILENCER:

- Demount discharge silencer
- Check rotors for damages or greasiness
- Flush compressor twice with 1/4L degreaser
- Check rubber compensator for cracks replace if necessary
- Check aluminium pipes and silencers for cracks and leakage
- Mount discharge silencer
- Check the indicator's piping for cracks and leakage

AIRFILTER:

- Take air filter lid off
- Check the lid's latches
- Check if the insulation material is secured in suction part if this isn't the case repair and finish with sealant
- Check functioning of air filter indicator
- Clear intake-side of degreaser residue
- Place a new air filter element

ENCLOSURE:

- Check the insulation material in the enclosure for damages (cover, back panel, floor panel) if necessary repair and finish with sealant
- Check if the fan louvers are open
- Check if the discharge silencer is clean (flow)
- Check the frame and brackets for potential cracks
- Check if the bolts of the brackets are secured
- Check the seal washers of the Storz coupling for cracks and leakage
- Check the functioning of the cover's latches
- Tighten the bolts of the mounting brackets

TRANSMISSION:

- Check the PTO-shaft for leeway in the cross journals
- Lubricate the PTO-shaft with EP grease (red)
- Tighten the bolts of the PTO-shaft flanges
- Check the automatic tensioner for leakage
- Check the seal for damages (replace if necessary)
- Change the oil and the seal every 5 years (ISO VG 68)
- Check the powerband for damages
- Check if the gearing of the powerband is complete
- Potential small holes in the powerband as a result of small stones between the powerband are no reason for replacement

TESTING:

- Operation test run of machine
- Check density of discharge sides
- Check pressure valve for 2.5 bar
- Check functioning of indicators
- Check the engine for unusual sounds
- Clean the window pane