

RTI INSTRUCTION AND OPERATING MANUAL

Compressor installation Cmax3
Powerband driven





Preface

This instruction and operating manual is required for compressor installations manufactured by the following company:

RTI Transport Installaties B.V.
Albert Schweitzerstraat 29
7131 PG Lichtenvoorde
Tel. + 31 (0)544-377050

The manual provides information about the following installation:

Alfons Haar Cmax3 powerband DRIVEN

Carefully read these instructions and the compressor instruction before setting up and going into operation. These manuals contain essential information that must be read to ensure interference-free operation and to achieve longevity.

Repairs, maintenance or conversion work shall only be carried out by authorised, trained and qualified personnel that are familiar with the current safety regulations.



Contents:

1	General	4
1.1	Contact details	4
1.2	Service facilities	4
1.3	Technical data compressor	4
1.4	Oil Cmax3 compressor	5
1.5	Oil cooler	6
2	Safety	7
2.1	General	7
2.2	Qualification and training personnel	7
2.3	Operating safety-conscious	7
2.4	Safety instructions operator	7
2.5	Modifications and repairing spare parts	7
2.6	Modifications installation	7
3	Mounting installation	8
3.1	Mounting instructions RTI installation powerband driven	8
3.2	Mounting instructions high air intake	9
4	Start-up	10
5	Maintenance installation	11
5.1	Inspection during operation	11
5.2	Weekly inspection	11
5.3	Monthly inspection	12
5.4	Half-yearly inspection	13
5.5	Inspection extreme use	13
5.6	Maintenance checklist	13

1 General

1.1 Contact details

Please mention the PO number when contacting us by phone or mail. You will find the PO number on the type plate of the installation.

Telephone number: (0031) 544-377050
 Fax: (0031) 544-376499
 Email: info@rti.nl

1.2 Service facilities

For addresses of service/technical support facilities, please visit our website www.rti.nl

1.3 Technical data compressors

Technical data

	<i>Cmax3 S</i>	<i>Cmax3 R</i> (also available as vacuum machine)	<i>Cmax3 H</i>
Weight:	109 kg	123 kg	133 kg
Speed:	1200–2100 rpm	900–1600 rpm	1200–2100 rpm
Flow rate:		570–1060 Nm ³ /h	
Inlet temperature:		max. 35°C	
Suction condition:		max. 50 mbar	
Temperature at 2 bar (g.):		175°C (at 20°C ambient condition)	
Oil cooler:		electr. or mechanical type	
Pressure:	2,5 bar (g.) at 50 mbar vacuum/20°C ambient condition		

Ancillaries

- ORVA2 – operated non return relief valve associated with
- ESS/Compressor Protection Box – the best protection for every compressor
- FCS – friction coupling to protect the compressor and PTO
- Cocoon – acoustic enclosure
- Silencer – absorptive
- LFDO – air filter
- LK – air cooler
- Hydraulic drive systems

The warranty can be extended up to 4 years with service and ancillaries.

Required power

Cmax3 R

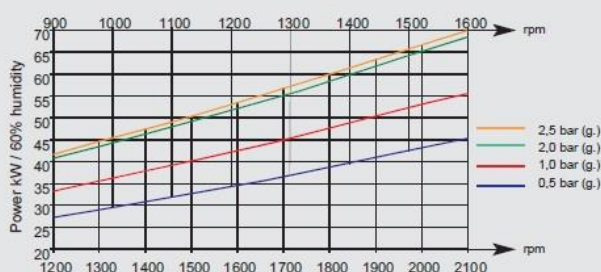

Cmax3 S, H, RS

Flow rate Nm³/h

Cmax3 R

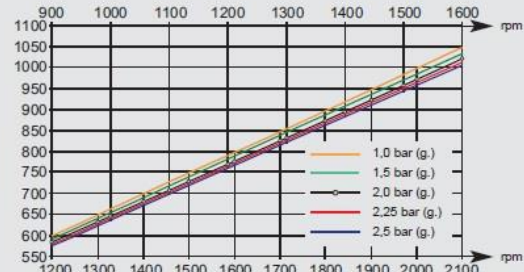

Cmax3 S, H, RS

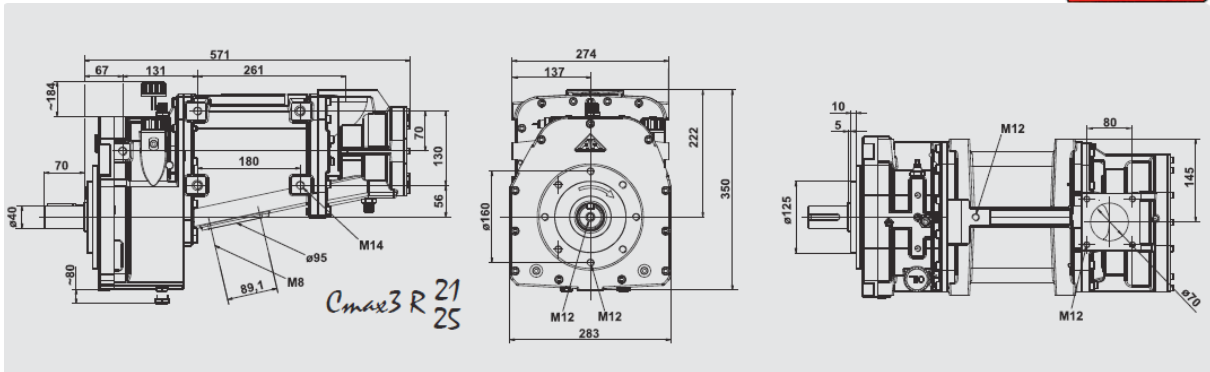

1.4 Oil Cmax3

Type	R21/25, R21+ VA	R21 HV/HS	L16/21
Weight compressor	109 kg	133 kg	123 kg
Weight compressor with oil	111.5 kg	135.5 kg	126 kg
Oil volume (Ca)	2,5 l	2,5 l	3 l
Let off volume (Ca)	2 l	2 l	2 l
First service after: or:	100 h 1 month	100 h 1 month	100 h 1 month
Subsequent service interval: or:	500 h 6 months	500 h 6 months	500 h 6 months
Oil type	Fully synthetic 5W50 or 10W50 Specification SJ/CD/EC	Fully synthetic 5W50 or 10W50 Specification SJ/CD/EC	Fully synthetic 5W50 or 10W50 Specification SJ/CD/EC

Oil pressure: The oil pressure has to be between 0.5 and 2.0 bar (g.).

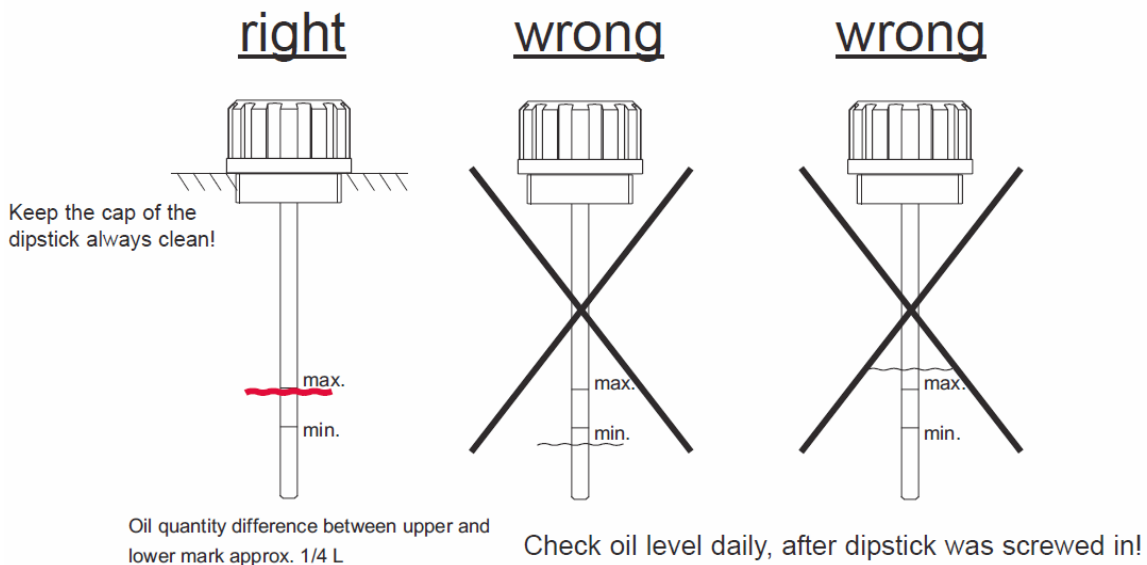

1.5 Oil cooler

It is important to keep the oil cooler clean to prevent the overheating of the compressor. The oil temperature cannot exceed 90° C.



Image 1.5.1 Oil cooler (art.no. 1342)



2 Safety

2.1 General

This operating manual provides important information concerning operation and maintenance of the installation that must be observed. Authorised personnel/the operator must read the manual carefully before going into operation and the manual must be kept in direct proximity of the installation.

2.2 Qualification and training personnel

Any work on the compressor such as operation and maintenance shall only be carried out by authorised, skilled and qualified personnel, who are familiar with the applicable safety regulations. Repairs, maintenance and conversion work shall only be carried out by authorised personnel.

2.3 Operating safety conscious

Essential safety regulations relating to the setting up, operation and maintenance of air compressors are covered by the following publications:

- Regulations for the prevention of accidents, in particular:
 - VBG 16 compressors
- Standards, in particular:
 - DIN EN 12100 Safety of machines
 - DIN EN 1012-1 Compressors and vacuum pumps, safety requirements

The latest edition of each of these regulations shall be applicable. Any special official codes and regulations, particularly safety regulations applicable to your operation in view of the local conditions shall be observed likewise. In the event of competing regulations, the most severe requirements shall apply.

2.4 Safety instructions operator

Securing the compressor's operational safety is the responsibility of the operator. Damaged or non-functioning parts must be replaced immediately. If combustible materials are to be handled by the compressor, it shall be ensured that the spontaneous-ignition temperature of any dust/air mixture will not be reached. VBG 16 prescribes that a temperature limit of max. 120° C should not be exceeded (measuring point prior to contact with the conveyed product).

2.5 Modifications and repairing spare parts

Unauthorized repair work and modifications are not permitted. Warranty doesn't apply to installations with a damaged seal. Original spare parts and accessories approved by the manufacturer contribute to safety. Using foreign spare parts and accessories may entail the loss of any liability for the consequences arising therefrom.

2.6 Modifications installation

Without approval from RTI, it is not permitted to make any alterations to the installation.

3 Mounting installation

3.1 Mounting instructions RTI installation powerband driven

- A While placing the installation on a pallet, make sure the installation is approximately 30 cm off the ground (raising the installation with timber if necessary).
- B Drive the installation up to the desired location next to the truck. Make sure the angle of the drive shaft is as small as possible. **Please find the maximum mounting angle in the mounting instructions provided by the truck manufacturer.**

The resulting angle can be 15° maximum!
 1° to 10° is good
 11° to 15° is excessive

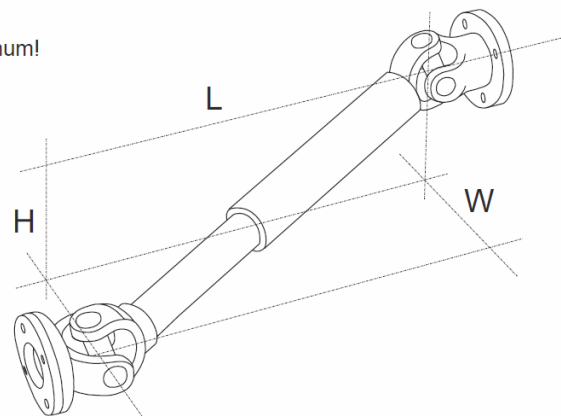

Image 3.1.1

- C Place the installation at the same level as the chassis and parallel to the truck. Measure the PTO-shaft. Make sure the installation doesn't exceed the width of the truck.
- D Measure the brackets and try to use all the holes in the chassis. Brackets should be painted or otherwise protected against corrosion.
- E The installation must be mounted with at least 3 brackets. (With a box or tank combination at least 4 brackets should be used)
- F Mark where the holes need to be, drill/punch the holes, paint the brackets in the colour of your choice and let them dry.
- G Mount the painted brackets onto the chassis with the bolts and nuts specified by the manufacturer.
- H Subsequently mount the installation onto the brackets with M14 bolts (8.8), washers, spring washers and nuts.

NOTE

With a vacuum installation the vacuum valve must be set to -0.5 bar. Please note: the vacuum valve should be set when testing the installation before initial operation. The vacuum valve has not been set when the installation is delivered as a building kit (without mounting by RTI).

3.2 Mounting instructions high air intake

- A Mount the high air intake behind the drivers cab with the supplied rubber buffers and blind riveting nuts.
- B Mount the flexible hose between the air filter and the high air intake.
- C Use safety rubbers or suspension brackets when attaching the hose between the chassis with tie wraps.
- D Check the functionality of the sliding joint connected to the high air intake; check to see if it can be taken off. The sliding joint should separate from the high air intake before the drivers cab is tilted.
- E Check the negative pressure after mounting (this should not be below 45 mbar).



Image 3.2.1



4 Start-up

Observe the following prior to start-up:

IT IS OF VITAL IMPORTANCE THAT THERE ARE NO PERSONS UNDERNEATH THE VEHICLE DURING START-UP AND DURING OPERATION!!

● Preservation

The rotors of the compressor are sprayed with an anti-corrosion agent prior to delivery. During the initial operation this agent will evaporate as the compressor heats up. Since the RTI-installations are all tested a few minutes, the anti-corrosion agent on the rotors will have evaporated.

● Topping up of lubricating oil

Check before start-up if the correct amount of lubricating oil is on the dipstick. The correct level corresponds to the mark on the dip stick. See chapter 1.4

● Checking the direction of rotation

Looking towards the drive shaft, the compressor must rotate clockwise.

The compressor must be started and stopped in a fully unloaded condition, without any back pressure.

Never start against any back pressure. (Remove blanking cap or connect hoses.)

● Switching-on

We refer to the truck's instruction booklet, to switch on the PTO (only with closed enclosure).

It is very important not to exceed the maximum speed range as reported in the inspection report and as displayed on the dashboard of the driver's cab.

Together with the compressor, the integral oil pump will also start to run and will ensure the supply of oil to lubricate the bearings and the gears. The oil pressure shall not fall below 0,3 bar. With cold oil, it may occur that the required oil pressure is built up only after a short operating time, due to higher viscosity. Check the air indicator clock. When "red", the compressor must be switched off. See inspection checklist.

● Vacuum installation

With a vacuum installation the vacuum valve must be set to -0.5 bar. Please note: the vacuum valve should be set when testing the installation before initial operation. The vacuum valve has not been set when the installation is delivered as a building kit (without mounting by RTI).

CAUTION

After a short period of time, the compressor will reach maximum running temperature.

When switched-on, it not permitted to loosen the catches on the enclosure!!

We recommend the use of safety gloves when disconnecting hoses or couplings from the enclosure, after the installation has been switched-on.

NOTE

When cleaning the tank vehicle by means of a steam jet device, water may penetrate inside the compressor via the oil seals. To avoid corrosion, the compressor shall be set into operation for a short period of time after cleaning.

The non-return valve installed in the discharge silencer is not intended to prevent flow-back of material. Its purpose is to prevent the reverse operation of the compressor for an extended period of time.

It is not permitted to use the attached relief valve as blow-off control valve.

5 Maintenance installation

5.1 INSPECTION DURING OPERATION

- A: Check the oil manometer before every start-up. The oil pressure must not drop below the minimum value of 0.3 bar, (normally 1-3 bar). When outside temperature is low it may take a few seconds before the oil pressure is visible.
- B: Check the air filter indicator.
If the red mark is visible, the air intake filter is soiled and poses a risk of overheating and damages.
- C: The safety valve must open at maximum air pressure.
This valve must NOT be used as blow-off valve. To prevent overheating in the enclosure the valve at the silo tank must blow off before the compressor valve does. (blow-off pressure 2.5 bar)
- D: Pay attention to any unusual sounds or peculiarities near the installation.

5.2 WEEKLY INSPECTION

ONLY CARRY OUT WHEN INSTALLATION IS COOL AND AT A STANDSTILL

- A: Check the level of lubricating oil weekly.
To achieve longevity of the compressor it is important the oil level remains between the indicated marks on the dip-stick (do not overfill).
- B: Check the air intake filter at regular intervals. Clean or replace the air filter if necessary.
* Please note that the air filter is reinserted in the same position (paying attention to the front and back of the element).



Image 5.2.1

Also check the functioning of the air indicator.

- C: It is important to check the airflow and cleanliness of the fan louvres to prevent overheating of the compressor.
(compressed air cooler and when installed the oil cooler)
- D: Check the tension of the V-belt/powerband and assess the wear of the belt.
Retighten the belt if you can press over 0.5 centimetre into the belt.

5.3 MONTHLY INSPECTION

ONLY CARRY OUT WHEN INSTALLATION IS COOL AND AT A STANDSTILL

This check may only be carried out by skilled mechanics. Observe the safety very carefully, the enclosure must be removed and rotating parts will be accessible.

- A: Lubricate cross journals of the PTO-shaft (after approx. 40 operating hours)
- B: Lubricate latches and padlock and check their functioning.
- C: Preserve the compressor when it has been at a standstill for a longer period of time. (lubricate the compressor's rotor with oil to prevent corrosion)

To carry out the following inspections it is necessary to start the installation without enclosure. Please note the dangers that can occur as a result of access to:

- hot parts as compressor and silencer (150 ° C)
- rotating parts such as the transmission and the fan
- high sound levels (> 85 dB)

HEARING PROTECTION OBLIGATED!!

DURING INSPECTION NO ONE IS ALLOWED UNDERNEATH THE VEHICLE!!

- D: Check the functioning of the safety valve.
Air pressure measured at the discharge flange of the compressor may not exceed a maximum gauge pressure of 2.5.
Potential pressure loss between compressor and silo tank of 0.2 up to 0.3 bar
- E: Check flanges/packing, rubber compensators etc. in the enclosure for air leakages to avoid loosening of the insulation material and overheating.
- F: Check the tension of the belts/power band. Retighten the belts if necessary. You should be able to press at least 0.5 centimetres into the middle of the belt after retightening.

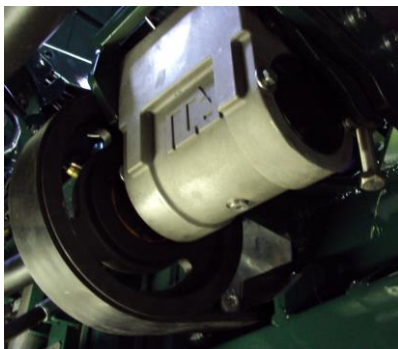

Stainless steel tension bolt M16x140 art.no. 16140

Image 5.3.1



5.4 HALFYEARLY INSPECTION

ONLY CARRY OUT WHEN INSTALLATION IS COOL AND AT A STANDSTILL

This check may only be carried out by skilled mechanics. Observe the safety very carefully, the enclosure must be removed and rotating parts will be accessible.

- A:** Change the lubricating oil simultaneously with the truck's engine oil, at least twice a year.
(oil type 5W50 or 10W50 synthetic oil)
- B:** Clean the oil filter. Please find the instructions to demount the oil filter in the manual provided with the installation.
- C:** Demount the non-return valve installed in the discharge silencer and check for proper functioning.
- D:** The aluminium bearing block (type 405) is supplied with 200 ml. oil (ISOVG68). Check the seals for damages/leakage.
Change the oil every 4 years (or every 3,500 hours).
- E** Change the compressor's oil filter every year.

NOTE: The operating instructions provided by the compressor manufacturer should be read carefully.

5.5 Inspection extreme use

With extreme use of the installation (animal feed) it is important to carry out the following actions in addition to the inspections mentioned in paragraph 5.1 to 5.4.

- | | |
|-----------|---|
| Weekly: | Check the level of lubricating oil
Clean air filter and oil filter
Check the tension of the belts/powerband
Check everything for leakage |
| Monthly | Lubricate cross journals and PTO-shaft |
| Quarterly | Change the oil
Clean magnetic plugs
Change air filters
Clean the compressed air cooler |

5.6 Maintenance/inspection list

Along with every maintenance inspection the maintenance checklist on the next page must be filled out. We recommend sending the checklist to RTI after filling it out.

Mail: info@rti.nl
Fax: (0031) 544-376499

Hold on to the checklist, the checklist can be handed to the mechanic when the next maintenance service is due or when the installation needs to be repaired. (Do not forget to take the checklist back with you)

Maintenance checklist



Firma	:	Date maintenance	:
Name mechanic	:	Compressor	:
Address	:	Serial number	:
	:	Installation-no.	: PO.....
Truck	:	Year manufactured	:
Truck nr.	:		:
Licence plate no.	:	Chassis:	No. KM driven:

Actions

COMPRESSOR:

- Drain oil
- Clean oil filter
- Clean magnetic plugs
- Check potential leakage machine
- Change + top up oil
- Check oil hose for potential cracks/damages

SILENCER:

- Demount discharge silencer
- Check rotors for damages or greasiness
- Flush compressor twice with 1/4L degreaser
- Check rubber compensator for cracks replace if necessary
- Check aluminium pipes and silencers for cracks and leakage
- Mount discharge silencer
- Check the indicator's piping for cracks and leakage

AIRFILTER:

- Take air filter lid off
- Check the lid's latches
- Check if the insulation material is secured in suction part if this isn't the case repair and finish with sealant
- Check functioning of air filter indicator
- Clear intake-side of degreaser residue
- Place a new air filter element

ENCLOSURE:

- Check the insulation material in the enclosure for damages (cover, back panel, floor panel) if necessary repair and finish with sealant
- Check if the fan louvers are open
- Check if the discharge silencer is clean (flow)
- Check the frame and brackets for potential cracks
- Check if the bolts of the brackets are secured
- Check the seal washers of the Storz coupling for cracks and leakage
- Check the functioning of the cover's latches
- Tighten the bolts of the mounting brackets

TRANSMISSION:

- Check the PTO-shaft for leeway in the cross journals
- Lubricate the PTO-shaft with EP grease (red)
- Tighten the bolts of the PTO-shaft flanges
- Check the automatic tensioner for leakage
- Check the seal for damages (replace if necessary)
- Change the oil and the seal every 5 years (ISO VG 68)
- Check the powerband for damages
- Check if the gearing of the powerband is complete
- Potential small holes in the powerband as a result of small stones between the powerband are no reason for replacement

TESTING:

- Operation test run of machine
- Check density of discharge sides
- Check pressure valve for 2.5 bar
- Check functioning of indicators
- Check the engine for unusual sounds
- Clean the window pane